

PART NUMBER	CYLINDER BORE	OUTSIDE DIAMETER	ROD DIAMETER	ROD THREAD	*A	B	C	D	*E	F	G	H	I	J	K	L	PORT*
TCL15	1.50"	1.875"	1.00"	0.875-14 UNF	10.25"	1.50"	0.76"	1.62"	4.50"	1.87"	0.87"	1.75"	2.00"	1.62"	0.93"	1.87"	SAE 6
TCL20	2.00"	2.375"	1.12"	1.125-12 UNF	10.25"	2.00"	1.01"	2.12"	3.62"	2.25"	1.12"	2.12"	2.62"	2.12"	0.81"	2.06"	SAE 8
TCL25	2.50"	2.875"	1.25"	1.125-12 UNF	10.25"	2.00"	1.01"	2.12"	3.62"	2.25"	1.12"	2.12"	2.62"	2.12"	0.81"	2.06"	SAE 8
TCL30	3.00"	3.50"	1.50"	1.250-12 UNF	10.25"	2.00"	1.01"	1.87"	3.62"	2.25"	1.12"	2.62"	2.62"	2.12"	0.87"	2.18"	SAE 8
TCL35	3.50"	4.00"	1.75"	1.500-12 UNF	10.25"	2.00"	1.01"	1.87"	3.62"	2.50"	1.12"	2.62"	2.75"	2.12"	0.93"	2.18"	SAE 8
TCL40	4.00"	4.50"	2.00"	1.500-12 UNF	10.25"	2.25"	1.01"	1.75"	3.62"	2.50"	1.12"	2.62"	2.75"	2.12"	1.00"	2.18"	SAE 8

1. FOR 8.00" STROKE : A = 12.25"  
 2. FOR 8.00" STROKE : E = 6.50" (1.50" BORE) E = 5.62" (2.00" TO 4.00" BORE)  
 DIMENSIONS A AND E ARE FOR REFERENCES ONLY AS CLEVIS IS ADJUSTABLE  
 \* NPT PORTS ARE ALSO AVAILABLE  
 MAXIMUM RETRACTED WORKING PRESSURE : 3000 PSI  
 MAXIMUM EXTENDED WORKING PRESSURE : SEE TABLE  
 RETRACTED AND STROKE TOLERANCE ± 1/8"

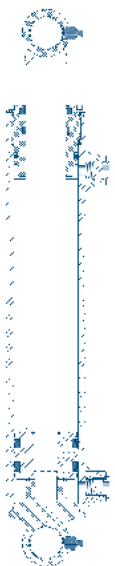



ADJUSTABLE FEMALE CLEVIS TYPE

PART NUMBER	BORE & STROKE	DIMENSIONS		ROD DIAMETER	PIN SIZE	PORTS*	COLUMN LOAD (LBS)	PRESSURE (PSI)	WEIGHT (LBS)
		RETRACTED	EXTENDED						
TCL1504-S	1.5" X 4"	14-1/4"	18-1/4"	1"	3/4"	SAE 6	5300	3000	10
TCL1506-S	1.5" X 6"	16-1/4"	22-1/4"				5300	3000	11
TCL1508-S	1.5" X 8"	18-1/4"	26-1/4"				5300	3000	12
TCL1508-ASAE*	1.5" X 8"	20-1/4"	28-1/4"				5300	3000	13
TCL1510-S	1.5" X 10"	20-1/4"	30-1/4"				5300	3000	13
TCL1512-S	1.5" X 12"	22-1/4"	34-1/4"				5300	3000	15
TCL1514-S	1.5" X 14"	24-1/4"	38-1/4"				5300	3000	16
TCL1516-S	1.5" X 16"	26-1/4"	42-1/4"				5200	2900	17
TCL1518-S	1.5" X 18"	28-1/4"	46-1/4"				4400	2400	18
TCL1520-S	1.5" X 20"	30-1/4"	50-1/4"				3700	2100	20
TCL1524-S	1.5" X 24"	34-1/4"	58-1/4"				2700	1500	22
TCL1528-S	1.5" X 28"	38-1/4"	66-1/4"				2100	1200	25
TCL1530-S	1.5" X 30"	40-1/4"	70-1/4"				1900	1000	26
TCL1532-S	1.5" X 32"	42-1/4"	74-1/4"				1700	900	27
TCL1534-S	1.5" X 34"	44-1/4"	78-1/4"				1500	800	28
TCL1536-S	1.5" X 36"	46-1/4"	82-1/4"				1300	700	29
TCL2004-S	2" X 4"	14-1/4"	18-1/4"	1-1/8"	1"	SAE 8	9400	3000	16
TCL2006-S	2" X 6"	16-1/4"	22-1/4"				9400	3000	17
TCL2008-S	2" X 8"	18-1/4"	26-1/4"				9400	3000	19
TCL2008-ASAE*	2" X 8"	20-1/4"	28-1/4"				9400	3000	19
TCL2010-S	2" X 10"	20-1/4"	30-1/4"				9400	3000	20
TCL2012-S	2" X 12"	22-1/4"	34-1/4"				9400	3000	22
TCL2014-S	2" X 14"	24-1/4"	38-1/4"				9400	3000	23
TCL2016-S	2" X 16"	26-1/4"	42-1/4"				8400	2600	25
TCL2018-S	2" X 18"	28-1/4"	46-1/4"				7000	2200	27
TCL2020-S	2" X 20"	30-1/4"	50-1/4"				5900	1900	28
TCL2024-S	2" X 24"	34-1/4"	58-1/4"				4400	1400	31
TCL2030-S	2" X 30"	40-1/4"	70-1/4"				3000	900	36
TCL2036-S	2" X 36"	46-1/4"	82-1/4"	2200	700	41			
TCL2504-S	2.5" X 4"	14-1/4"	18-1/4"	1-1/4"	1"	SAE 8	14700	3000	19
TCL2506-S	2.5" X 6"	16-1/4"	22-1/4"				14700	3000	20
TCL2508-S	2.5" X 8"	18-1/4"	26-1/4"				14700	3000	22
TCL2508-ASAE*	2.5" X 8"	20-1/4"	28-1/4"				14700	3000	23
TCL2510-S	2.5" X 10"	20-1/4"	30-1/4"				14700	3000	24
TCL2512-S	2.5" X 12"	22-1/4"	34-1/4"				14700	3000	26
TCL2514-S	2.5" X 14"	24-1/4"	38-1/4"				14700	3000	28
TCL2516-S	2.5" X 16"	26-1/4"	42-1/4"				12800	2600	30
TCL2518-S	2.5" X 18"	28-1/4"	46-1/4"				10700	2100	32
TCL2520-S	2.5" X 20"	30-1/4"	50-1/4"				9100	1800	34
TCL2524-S	2.5" X 24"	34-1/4"	58-1/4"				6700	1300	38
TCL2530-S	2.5" X 30"	40-1/4"	70-1/4"				4600	900	44
TCL2536-S	2.5" X 36"	46-1/4"	82-1/4"	3400	600	49			

\* NPT PORTS ARE ALSO AVAILABLE.  
NOTE : COLUMN LOAD IS THE MAXIMUM PUSHING LOAD SUGGESTED USING A MINIMUM SAFETY FACTOR OF 2 AND BASED ON A PIN TO PIN MOUNTING CALCULATION.

\* ASAE = AMERICAN SOCIETY OF AGRICULTURE ENGINEERS  
DESIGNATES AN INDUSTRY MOUNTING STANDARD FOR 8" AND 16" STROKE CYLINDERS

HYDRO CUSTOM IS NOT RESPONSIBLE FOR INCORRECT RESULTS OBTAINED WITH FIGURES IN THIS DOCUMENT. INFORMATION IS FOR REFERENCE ONLY. NO OTHER CONDITIONS ARE EXPRESSED OR IMPLIED.



ADJUSTABLE FEMALE CLEVIS TYPE									
PART NUMBER	BORE & STROKE	DIMENSIONS		ROD DIAMETER	PIN SIZE	PORTS*	COLUMN LOAD (LBS)	PRESSURE (PSI)	WEIGHT (LBS)
		RETRACTED	EXTENDED						
TCL3004-S	3" X 4"	14-1/4"	18-1/4"	1-1/2"	1"	SAE 8	21200	3000	24
TCL3006-S	3" X 6"	16-1/4"	22-1/4"				21200	3000	26
TCL3008-S	3" X 8"	18-1/4"	26-1/4"				21200	3000	29
TCL3008-ASAE*	3" X 8"	20-1/4"	28-1/4"				21200	3000	29
TCL3010-S	3" X 10"	20-1/4"	30-1/4"				21200	3000	31
TCL3012-S	3" X 12"	22-1/4"	34-1/4"				21200	3000	33
TCL3014-S	3" X 14"	24-1/4"	38-1/4"				21200	3000	36
TCL3016-S	3" X 16"	26-1/4"	42-1/4"				21200	3000	38
TCL3016-ASAE*	3" X 16"	31-1/2"	47-1/2"				21200	3000	38
TCL3018-S	3" X 18"	28-1/4"	46-1/4"				21200	3000	41
TCL3020-S	3" X 20"	30-1/4"	50-1/4"				18800	2600	43
TCL3024-S	3" X 24"	34-1/4"	58-1/4"				14000	1900	48
TCL3030-S	3" X 30"	40-1/4"	70-1/4"				9600	1300	56
TCL3036-S	3" X 36"	46-1/4"	82-1/4"				7000	900	63
TCL3504-S	3.5" X 4"	14-1/4"	18-1/4"	1-3/4"	1"	SAE 8	28800	3000	29
TCL3506-S	3.5" X 6"	16-1/4"	22-1/4"				28800	3000	32
TCL3508-S	3.5" X 8"	18-1/4"	26-1/4"				28800	3000	35
TCL3508-ASAE*	3.5" X 8"	20-1/4"	28-1/4"				28800	3000	36
TCL3510-S	3.5" X 10"	20-1/4"	30-1/4"				28800	3000	38
TCL3512-S	3.5" X 12"	22-1/4"	34-1/4"				28800	3000	41
TCL3514-S	3.5" X 14"	24-1/4"	38-1/4"				28800	3000	44
TCL3516-S	3.5" X 16"	26-1/4"	42-1/4"				28800	3000	47
TCL3516-ASAE*	3.5" X 16"	31-1/2"	47-1/2"				28800	3000	47
TCL3518-S	3.5" X 18"	28-1/4"	46-1/4"				28800	3000	50
TCL3520-S	3.5" X 20"	30-1/4"	50-1/4"				28800	3000	53
TCL3524-S	3.5" X 24"	34-1/4"	58-1/4"				26000	2700	59
TCL3530-S	3.5" X 30"	40-1/4"	70-1/4"				17900	1800	68
TCL3536-S	3.5" X 36"	46-1/4"	82-1/4"				13000	1300	77
TCL4004-S	4" X 4"	14-1/4"	18-1/4"	2"	1"	SAE 8	37600	3000	35
TCL4006-S	4" X 6"	16-1/4"	22-1/4"				37600	3000	38
TCL4008-S	4" X 8"	18-1/4"	26-1/4"				37600	3000	42
TCL4008-ASAE*	4" X 8"	20-1/4"	28-1/4"				37600	3000	43
TCL4010-S	4" X 10"	20-1/4"	30-1/4"				37600	3000	46
TCL4012-S	4" X 12"	22-1/4"	34-1/4"				37600	3000	49
TCL4014-S	4" X 14"	24-1/4"	38-1/4"				37600	3000	53
TCL4016-S	4" X 16"	26-1/4"	42-1/4"				37600	3000	57
TCL4016-ASAE*	4" X 16"	31-1/2"	47-1/2"				37600	3000	57
TCL4018-S	4" X 18"	28-1/4"	46-1/4"				37600	3000	60
TCL4020-S	4" X 20"	30-1/4"	50-1/4"				37600	3000	64
TCL4024-S	4" X 24"	34-1/4"	58-1/4"				37600	3000	71
TCL4030-S	4" X 30"	40-1/4"	70-1/4"				30500	2400	82
TCL4036-S	4" X 36"	46-1/4"	82-1/4"				22200	1700	93

\* NPT PORTS ARE ALSO AVAILABLE.  
 NOTE : COLUMN LOAD IS THE MAXIMUM PUSHING LOAD SUGGESTED USING A MINIMUM SAFETY FACTOR OF 2 AND BASED ON A PIN TO PIN MOUNTING CALCULATION.

\* ASAE = AMERICAN SOCIETY OF AGRICULTURE ENGINEERS  
 DESIGNATES AN INDUSTRY MOUNTING STANDARD FOR 8" AND 16" STROKE CYLINDERS

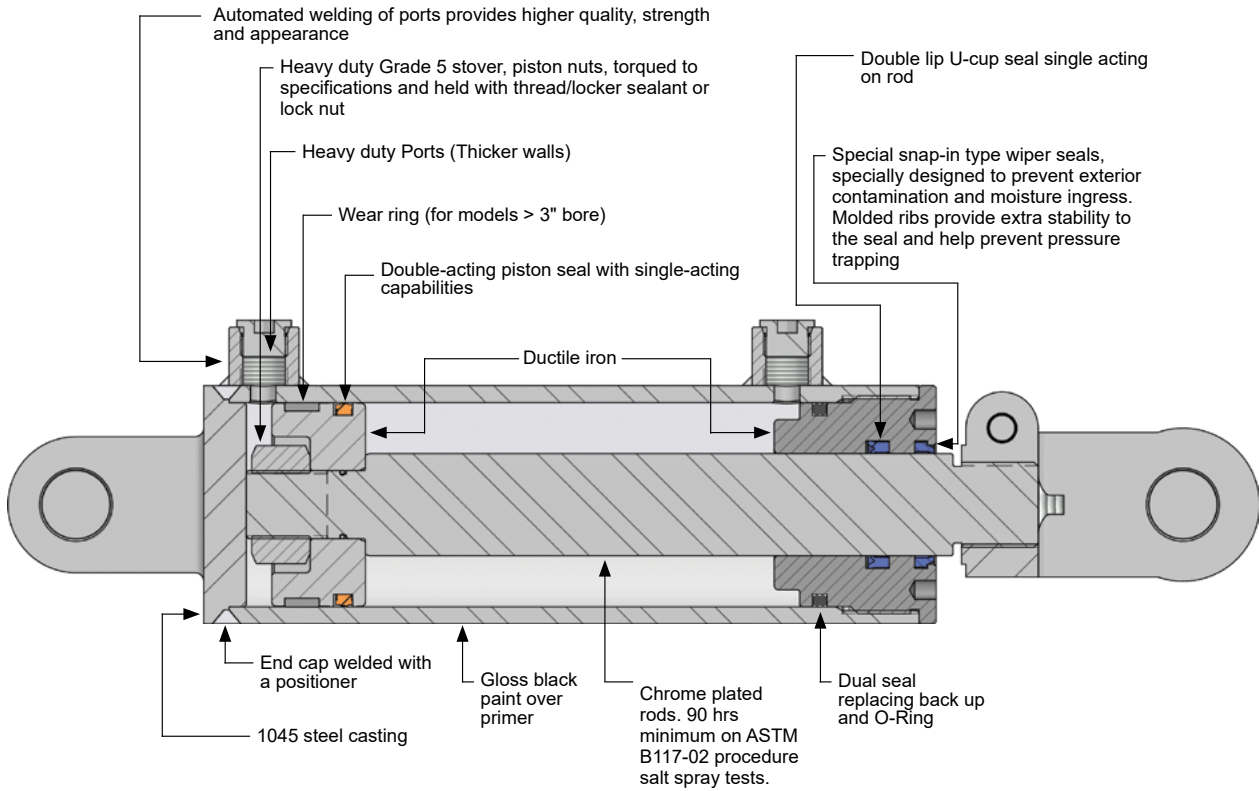

SEAL TEMPERATURE RANGE : -30°C / +100°C (-22°F / +212°F)  
 SEAL MAXIMUM SPEED : 3 FT / SEC

- All seals are top grade/first quality North American made
- All components are CNC machined for higher accuracy and conformity
- Quality controlled in China by qualified Canadian technicians
- 100% tested. All cylinders are submitted to static and dynamic pressure tests to recommended specifications

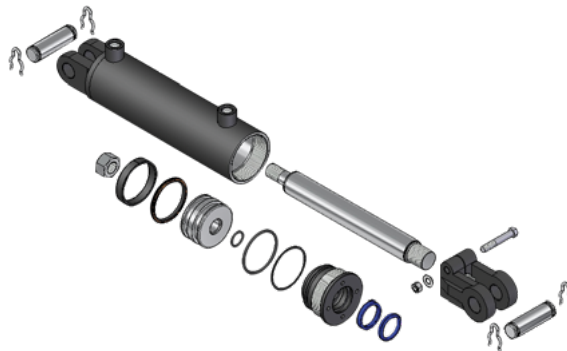

HYDRO CUSTOM IS NOT RESPONSIBLE FOR INCORRECT RESULTS OBTAINED WITH FIGURES IN THIS DOCUMENT. INFORMATION IS FOR REFERENCE ONLY. NO OTHER CONDITIONS ARE EXPRESSED OR IMPLIED.